

Standard cross roller rail sets

L1000 & L1001

- Seven rail profiles (Sizes 1-12)
- Lengths: 20mm to 1 metre
- L1000 standard rail set
- L1001 corrosion resistant rail sets

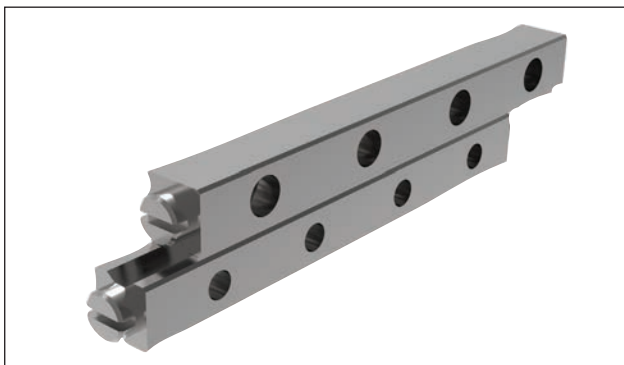

Deep groove and anti-creep rail sets

L1002 + L1003

- 3 x load capacity of standard rail sets (due to deep V groove)
- Two rail profiles (Sizes 4 & 6)
- Lengths 50mm to 400mm
- Anti-creep versions for high acceleration applications



Needle roller rail sets

L1004

- Heavy load ratings and needle rollers are used
- Five rail profile size
- Lengths: 200mm to 1.2 metres

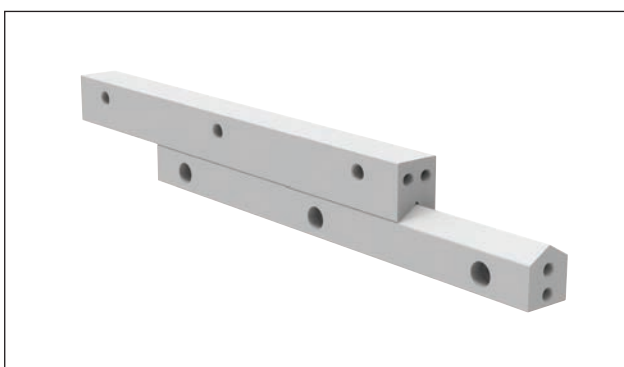

Anti-friction coated rail sets

L1005 & L1006

- Same profile as needle roller rails but contact face Teflon coated.
- Ideal for harsh, dirty conditions
- Vibration damping characteristics



L1001

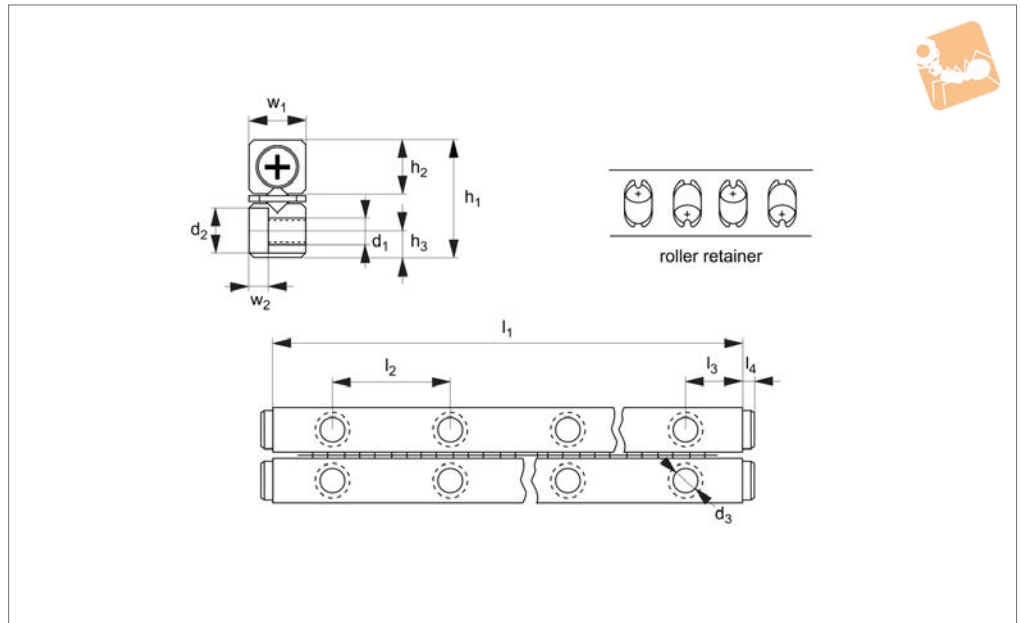

Material

Stainless steel rail and rollers (AISI 440C).
Hardness 60±2 HRC. Stainless steel roller
retainer (AISI 304).

Technical Notes

Supplied in sets of 4 rails (with 2 roller
cages and 8 end screws as standard). See
table for number of rollers in each cage.

Crossed roller cages can be cut to length to
alter stroke - but this affects load rating,
please see technical pages.

Order No.	l_1	Stroke max.	w_1	h_1 +0 -0.3	h_2	h_3	l_2	l_3	l_4	No. of rollers	Dyn. load C kN max.	Static load C_0 kN max.	d_1	d_2	d_3	w_2	Weight kg
L1001.01-020	20	13	4	8,5	3,9	1,8	10	5	1,3	5	0,63	0,72	1,65	3,0	M 2	1,4	0,01
L1001.01-030	30	21	4	8,5	3,9	1,8	10	5	1,3	7	0,88	1,01	1,65	3,0	M 2	1,4	0,01
L1001.01-040	40	29	4	8,5	3,9	1,8	10	5	1,3	9	1,13	1,30	1,65	3,0	M 2	1,4	0,02
L1001.01-050	50	37	4	8,5	3,9	1,8	10	5	1,3	11	1,38	1,58	1,65	3,0	M 2	1,4	0,02
L1001.01-060	60	45	4	8,5	3,9	1,8	10	5	1,3	13	1,63	1,88	1,65	3,0	M 2	1,4	0,03
L1001.01-070	70	53	4	8,5	3,9	1,8	10	5	1,3	15	1,88	2,16	1,65	3,0	M 2	1,4	0,03
L1001.01-080	80	61	4	8,5	3,9	1,8	10	5	1,3	17	2,13	2,45	1,65	3,0	M 2	1,4	0,03
L1001.02-030	30	24	6	12	5,5	2,5	15	7,5	1,5	5	1,47	1,46	2,55	4,4	M 3	2,0	0,03
L1001.02-045	45	30	6	12	5,5	2,5	15	7,5	1,5	8	2,34	2,34	2,55	4,4	M 3	2,0	0,04
L1001.02-060	60	44	6	12	5,5	2,5	15	7,5	1,5	10	2,93	2,92	2,55	4,4	M 3	2,0	0,06
L1001.02-075	75	58	6	12	5,5	2,5	15	7,5	1,5	12	3,52	3,50	2,55	4,4	M 3	2,0	0,07
L1001.02-090	90	72	6	12	5,5	2,5	15	7,5	1,5	14	4,10	4,09	2,55	4,4	M 3	2,0	0,08
L1001.02-105	105	86	6	12	5,5	2,5	15	7,5	1,5	16	2,50	4,34	2,55	4,0	M 3	2,0	0,10
L1001.02-120	120	100	6	12	5,5	2,5	15	7,5	1,5	18	5,27	5,26	2,55	4,4	M 3	2,0	0,11
L1001.02-135	135	106	6	12	5,5	2,5	15	7,5	1,5	21	6,15	6,13	2,55	4,4	M 3	2,0	0,13
L1001.02-150	150	120	6	12	5,5	2,5	15	7,5	1,5	23	6,74	6,72	2,55	4,4	M 3	2,0	0,14
L1001.02-165	165	134	6	12	5,5	2,5	15	7,5	1,5	25	7,33	7,30	2,55	4,4	M 3	2,0	0,15
L1001.02-180	180	148	6	12	5,5	2,5	15	7,5	1,5	27	7,91	7,88	2,55	4,4	M 3	2,0	0,17
L1001.03-050	50	34	8	18	8,3	3,5	25	12,5	2,0	7	4,47	5,33	3,3	6,0	M 4	3,1	0,10
L1001.03-075	75	54	8	18	8,3	3,5	25	12,5	2,0	10	6,38	7,61	3,3	6,0	M 4	3,1	0,15
L1001.03-100	100	74	8	18	8,3	3,5	25	12,5	2,0	13	8,29	9,89	3,3	6,0	M 4	3,1	0,20
L1001.03-125	125	104	8	18	8,3	3,5	25	12,5	2,0	15	9,57	11,4	3,3	6,0	M 4	3,1	0,24
L1001.03-150	150	124	8	18	8,3	3,5	25	12,5	2,0	18	11,5	13,7	3,3	6,0	M 4	3,1	0,29
L1001.03-175	175	144	8	18	8,3	3,5	25	12,5	2,0	21	13,4	16,0	3,3	6,0	M 4	3,1	0,34
L1001.03-200	200	164	8	18	8,3	3,5	25	12,5	2,0	24	15,3	18,3	3,3	6,0	M 4	3,1	0,38
L1001.03-225	225	184	8	18	8,3	3,5	25	12,5	2,0	27	17,2	20,6	3,3	6,0	M 4	3,1	0,43
L1001.03-250	250	204	8	18	8,3	3,5	25	12,5	2,0	30	19,1	22,8	3,3	6,0	M 4	3,1	0,48
L1001.03-275	275	224	8	18	8,3	3,5	25	12,5	2,0	33	21,1	25,1	3,3	6,0	M 4	3,1	0,53
L1001.03-300	300	244	8	18	8,3	3,5	25	12,5	2,0	36	23,0	27,4	3,3	6,0	M 4	3,1	0,57
L1001.04-080	80	54	11	22	10	4,5	40	20	2,0	8	9,84	9,36	4,3	7,5	M 5	4,1	0,26
L1001.04-120	120	92	11	22	10	4,5	40	20	2,0	11	13,5	12,9	4,3	7,5	M 5	4,1	0,39
L1001.04-160	160	130	11	22	10	4,5	40	20	2,0	14	17,2	16,4	4,3	7,5	M 5	4,1	0,51
L1001.04-200	200	154	11	22	10	4,5	40	20	2,0	18	22,1	21,1	4,3	7,5	M 5	4,1	0,64



Stainless Crossed Roller Rail Sets

corrosion resistant

Linear Rail Sets



Order No.	l ₁	Stroke max.	w ₁	h ₁ +0 -0.3	h ₂	h ₃	l ₂	l ₃	l ₄	No. of rollers	Dyn. load C kN max.	Static load C ₀ kN max.	d ₁	d ₂	d ₃	w ₂	Weight kg
L1001.04-240	240	192	11	22	10	4,5	40	20	2,0	21	25,8	24,6	4,3	7,5	M 5	4,1	0,76
L1001.04-280	280	230	11	22	10	4,5	40	20	2,0	24	29,5	28,1	4,3	7,5	M 5	4,1	0,89
L1001.04-320	320	254	11	22	10	4,5	40	20	2,0	28	34,4	32,8	4,3	7,5	M 5	4,1	1,01
L1001.04-360	360	292	11	22	10	4,5	40	20	2,0	31	38,1	36,3	4,3	7,5	M 5	4,1	1,14
L1001.04-400	400	330	11	22	10	4,5	40	20	2,0	34	41,8	39,8	4,3	7,5	M 5	4,1	1,27
L1001.04-440	440	354	11	22	10	4,5	40	20	2,0	38	46,7	44,5	4,3	7,5	M 5	4,1	1,39
L1001.04-480	480	392	11	22	10	4,5	40	20	2,0	41	50,4	48,0	4,3	7,5	M 5	4,1	1,51
L1001.06-100	100	80	15	31	14	6	50	25	2,0	7	18,0	18,4	5,3	9,5	M 6	5,2	9,62
L1001.06-150	150	108	15	31	14	6	50	25	2,0	11	28,3	29,0	5,3	9,5	M 6	5,2	0,93
L1001.06-200	200	154	15	31	14	6	50	25	2,0	14	36,0	36,9	5,3	9,5	M 6	5,2	1,24
L1001.06-250	250	200	15	31	14	6	50	25	2,0	17	43,7	44,8	5,3	9,5	M 6	5,2	1,55
L1001.06-300	300	246	15	31	14	6	50	25	2,0	20	51,4	52,6	5,3	9,5	M 6	5,2	1,85
L1001.06-350	350	274	15	31	14	6	50	25	2,0	24	61,7	63,2	5,3	9,5	M 6	5,2	2,16
L1001.06-400	400	320	15	31	14	6	50	25	2,0	27	69,4	71,1	5,3	9,5	M 6	5,2	2,47
L1001.06-450	450	366	15	31	14	6	50	25	2,0	30	77,1	79,0	5,3	9,5	M 6	5,2	2,77
L1001.06-500	500	412	15	31	14	6	50	25	2,0	33	84,8	86,9	5,3	9,5	M 6	5,2	3,08
L1001.06-550	550	458	15	31	14	6	50	25	2,0	36	92,5	94,8	5,3	9,5	M 6	5,2	3,38
L1001.06-600	600	486	15	31	14	6	50	25	2,0	40	103,0	105,0	5,3	9,5	M 6	5,2	3,69

LINEAR RAIL SETS



Our cross roller rail sets are of the highest quality.

- Close tolerance $\pm 5\mu$
- Speeds up to 50 m/min
- Temperature range -40°C to $+80^{\circ}\text{C}$ up to $+250^{\circ}\text{C}$ if applying a temperature factor
- Through hardened to 60 ± 2 HRC
- Acceleration up to 50 m/sec^2
- Typical 0.003 coefficient of friction dependent on mounting surface accuracy

Expected life calculation:

$$\text{Life (Km)} L = (C/P)^{3.3} \times 1.15 \times 10^5 \text{m}$$

C = effective dynamic load (N)

P = equivalent load (N)

Working life calculation:

$$L_h \text{ (hours)} = \frac{L \times 10^6}{2 \times L_s \times n \times 60}$$

L = Life (Km), see above

L_s = Stroke Length (mm)

n = Number of operations/min

Accuracy Specification:

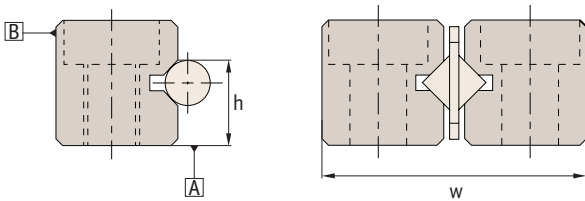

Accuracy level	
Parallelism of rolling plane A&B	graph below
Allowable height tolerance (h)	$\pm 0,02$
Paired mutual height tolerance (h)	0,01
Allowable width tolerance (w)	$+0, -0,02$

Parallelism

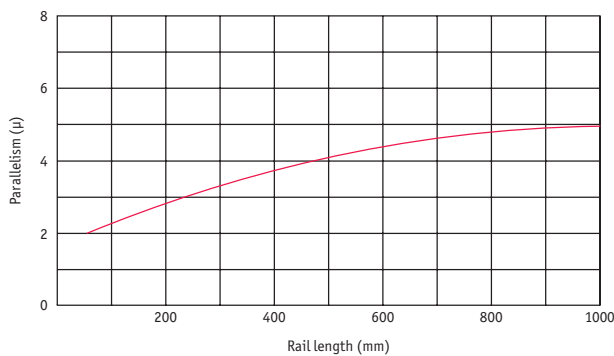

Lubrication:

The units are lubricated with lithium soap lubricant. Relubricate if required.

Straightness		
Length (mm)		Straightness (μ)
Above	Below	
0	50	2,0
50	100	2,0
100	160	3,0
160	310	3,0
310	510	4,0
510	600	4,0

(Ra 0,2 μm)

Load capacity depends on:

- Rail size
- Number of rollers in cage
- Load rating = number of rollers x load rating/roller
- Number of rollers (N_r) = cage length (L_c) / pitch p
- Cage length affects the stroke and travel of the system

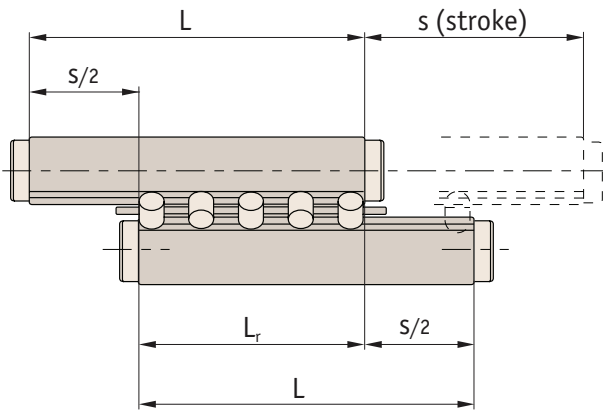

Load calculations

Calculations of retainer length and number of rollers:

$$L_r = \frac{L - S}{2}$$

L_r = distance between two rollers in ends of retainer (mm)

L = rail length (mm)

S = stroke length (mm)

Worked example:

Assume L1000.09-400 with a stroke of 250mm:

Cage length = $400 - (250/2) = 275$ mm

Roller $\varnothing = 9$ mm with a pitch (see table) of 18mm:

Number of rollers = $275/18 = 15$

Load rating of system = load/roller* x no. of rollers
(a pair of rollers) = $2420N \times 15$
= 36,300N

*See product table for allowable load per roller.

Allowable load rating with a 3x safety factor compared to static load.

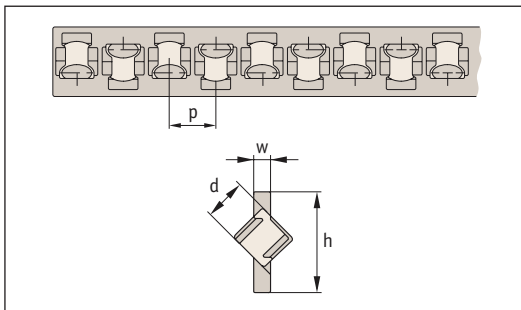

Plastic cage



L1008.###-PR-xxx

Plastic cage with steel rollers,
for horizontal and vertical use.

Steel cage



L1008.###-AA-xxx

Steel cage with steel rollers,
for horizontal use only.

Order no.	d	p	h	w	Cage material
L1008.020-PR-xxx	2	3,9	5	0,75	Plastic - black
L1008.030-PR-xxx	3	5,0	7	1,00	Plastic - black
L1008.060-PR-xxx	6	8,5	14	2,00	Plastic - black
L1008.090-PR-xxx	9	14,0	20	3,00	Plastic - black
L1008.020-AA-xxx	2	4	5,5	0,80	Steel
L1008.030-AA-xxx	3	5	7,5	0,50	Steel
L1008.060-AA-xxx	6	12	14	0,80	Steel
L1008.090-AA-xxx	9	18	19,5	1,00	Steel
L1008.120-AA-xxx	12	22	25	1,20	Steel

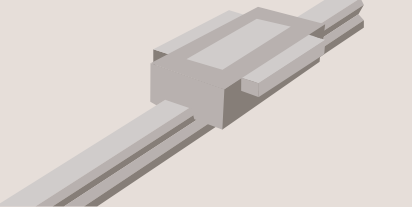

Linear Rail Sets

Roller elements & end pieces



Plastic cage (type PR)

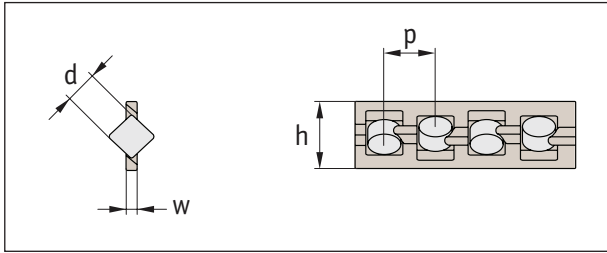

Steel cage (type AA)

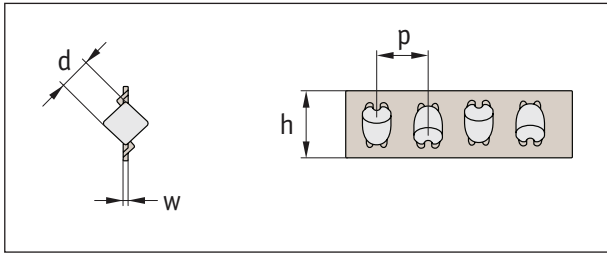

Roller load ratings (per roller)			
Rail size	Max. dynamic load C_0 N	Max. static load C N	Allowable* load N
1	125	144	48
2	290	290	95
3	630	760	250
4	1230	1170	390
6	2570	2630	870
9	7190	7270	2420
12	14700	13100	4300

The more rollers the greater the load capacity

* Allowable load is 1/3 of max. static load/roller, to allow a safety factor in calculations of 3.

End pieces

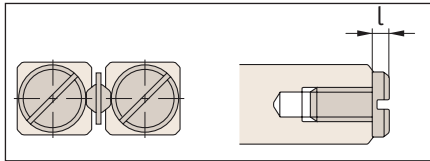

Type GA

- For horizontal applications, most used.

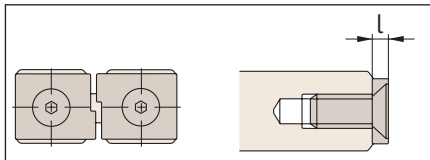

Type GB

- For horizontal or vertical applications.

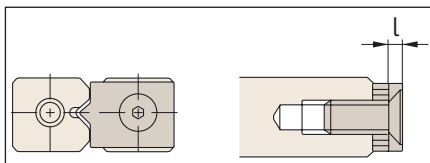

Type GC

- For horizontal or vertical applications.
- Mount on longer rail only.

Rail size	Type		
	GA l	GB l	GC l
1	1,5	-	-
2	2	3	-
3	2	2	3
6	3	3	5
9	3	4	6
12	3	5	8

End screws

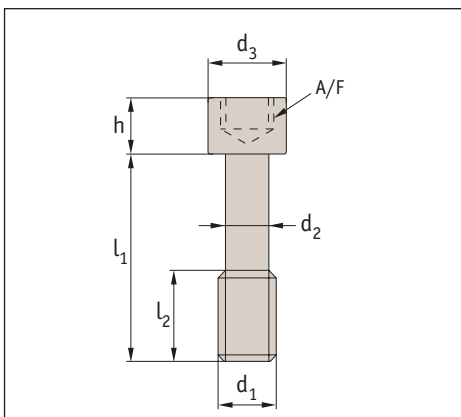

Rail	h	d ₁	d ₂	d ₃	l ₁	l ₂	A/F
3	3	M3	2,3	5	12	5	2,5
6	5	M5	3,9	8	20	8	4
9	6	M6	4,6	8,5	30	12	5
12	8	M8	6,25	11,3	40	17	6

Recommended torque for pre-load screws

Rail size	Set screw size	Torque to Nm
1	M2	0,008
2	M3	0,012
3	M4	0,05
4	M4	0,08
6	M5	0,2
9	M6	0,4

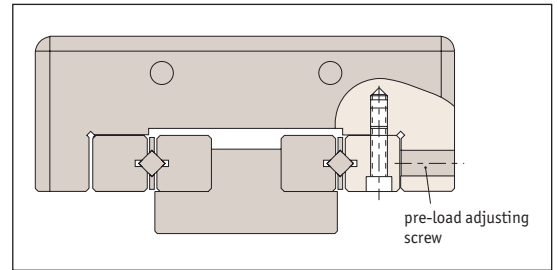

Fixing screws

Rail size	d ₁	d ₂	d ₃	h	l ₁	l ₂	A/F	Torque to Nm
3	M3	2,3	5	3	12	5	2,5	1,0
4	M4	3,1	5,8	4	15	7	3	2,4
6	M5	3,9	8	5	20	8	4	4,8
9	M6	4,6	8,5	6	30	12	5	8,1
11	M8	6,25	11,3	8	40	17	6	19,7

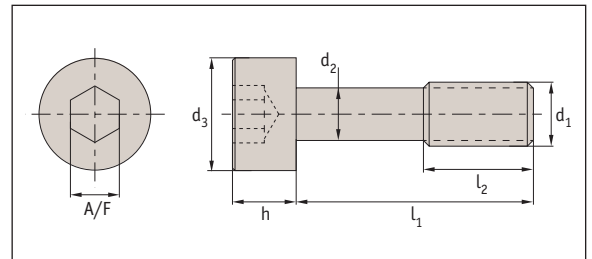

Important notes:

Inaccurate assembly

Inaccurate assembly or machining of surfaces will lead to low accuracy and cage creep which affects system reliability and life.

Cage creep

High speeds or off-set loads, high levels of vibration can cause cage creep.

End screws

These function to prevent the cage falling out. They are not designed as end stops. If this is required it should be designed into your system.

Ensure structure is rigid and machined accurately.

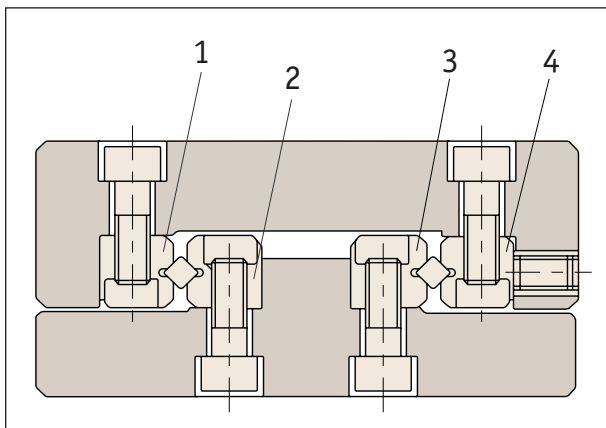

- Assemble rails 2 and 3
- Check for run-out and parallelism
- Install rails 3 and 4 without tightening screws
- Install cages and end pieces
- Slide the moving part to end of the travel to allow the centering of the cage
- Tighten the preload screws to eliminate clearance
- Tighten the retaining screws
- Ensure the extended end stops are hit before the cage hits the screws or end piece



Installation surfaces

All burrs, dents, dust, etc. on the table and base need to be reduced.

Pre-load adjustment; too much preload can cause damage & reduced life. We recommend to use no or a small amount of pre-load.

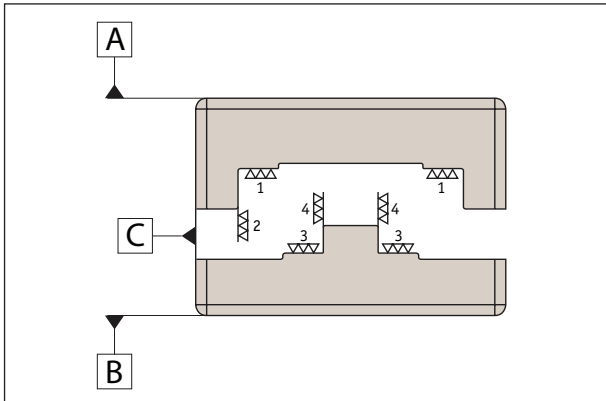

Adjusting screw

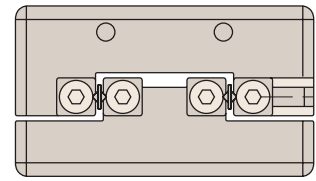

Clamp

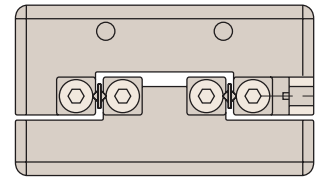

Taper block

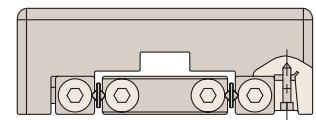

Assembly process

1. Apply a low viscosity oil on contact surface, fix rail (1,2 & 3) lightly.

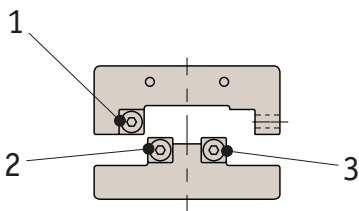

2. Temporarily fix the rail in adjusted side (4)

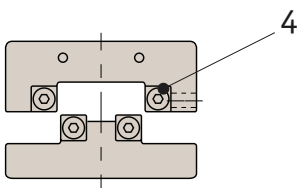

3. Disassemble end screw from one end, and carefully insert roller retainer to nearly the centre of the rail.

Replace the end screw.

Slowly move table back and forth to the rail end, and adjust roller retainer position to rail centre.

4. Fix gauges both in centre and the side of the table.

assembly position of gauge

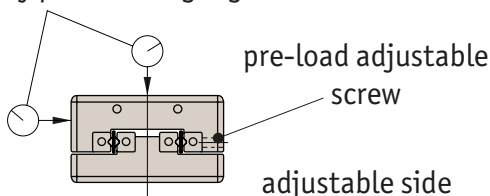

5. Move the table to one end and adjust pre-load screw slightly.

assembly position of pre-load adjusting screw

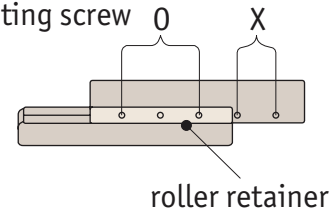

6. Move table to the other end and repeat.

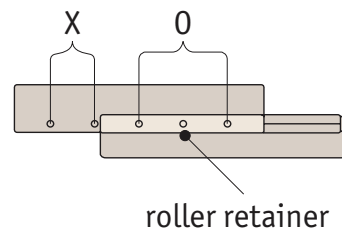

7. Return the table back to centre and lock the pre-load adjusting screw slightly. Adjust the clearance of table to zero. For final adjustment of preload, set correct torque value with a torque wrench and prepare to lock the rail fixing screw.

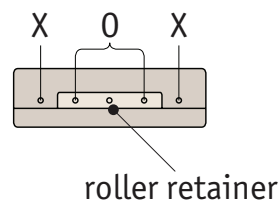

7. Finally securely lock the rail.

O : Loading on to pre-load adjusting screw

X : Loading off to pre-load adjusting screw